

MDE Series

Molding Power Inductors

Size 252012

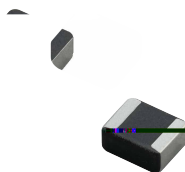

FEATURES

- High saturation current realized by material properties
- Low DC resistance to achieve high conversion efficiency
- Low Profile.
- Magnetically shielded structure to accomplish high resolution in EMC protection.
-
- Operating temperature: -40 to +125 °C
- Quantity: 3000PCS

APPLICATION

-
-
-
-

Dimensions: [mm]

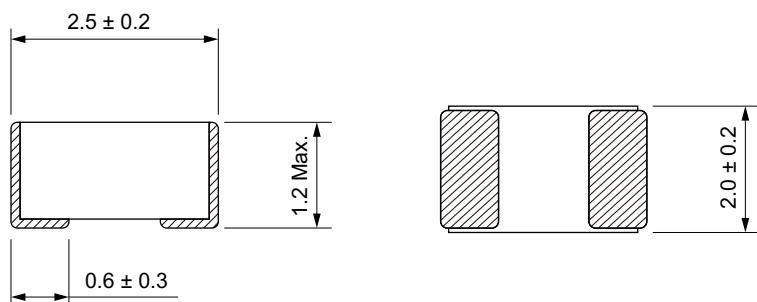

Land Pattern: [mm]

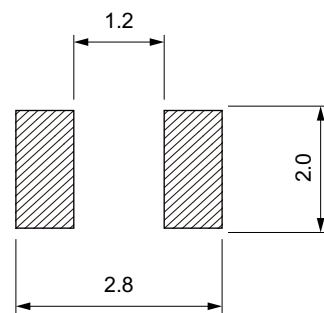

Electrical Properties:

Part No	Inductance @ 1MHz/1V (μH)	Tolerance	DC Resistance Typ. (mΩ)	DC Resistance Max. (mΩ)	Saturation Current Typ. (A)	Saturation Current Max. (A)	Temperature Rise Current Typ. (A)	Temperature Rise Current Max. (A)

Temperature rising current will cause the coil temperature approximate T40 °C
 Saturation current will cause to drop approximately 30%

Typical Electrical Characteristics:

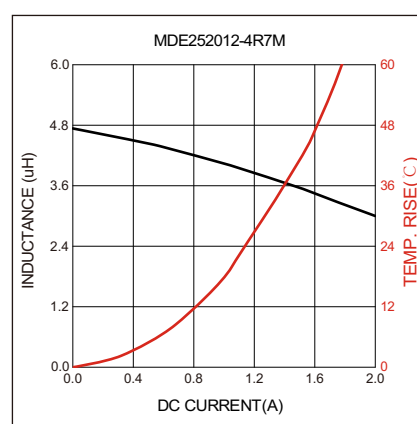
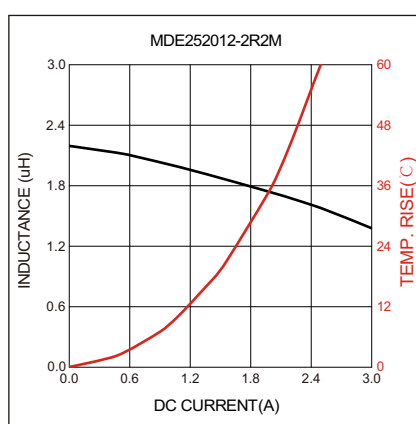
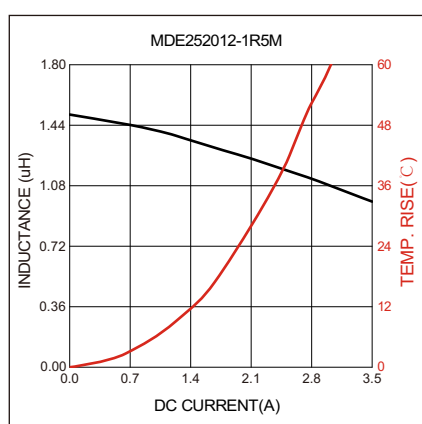
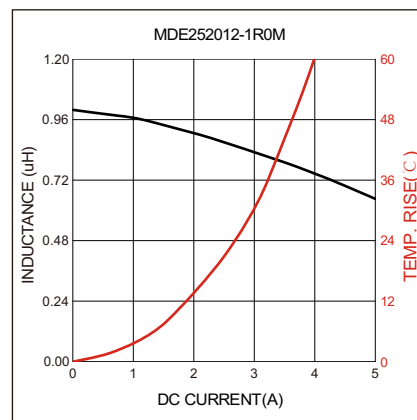
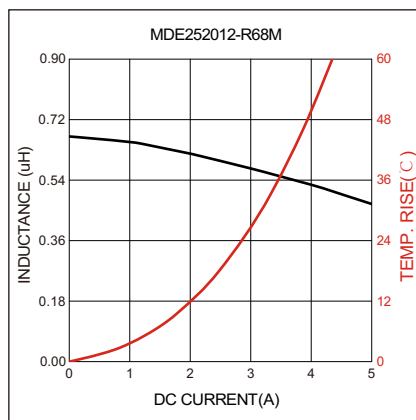
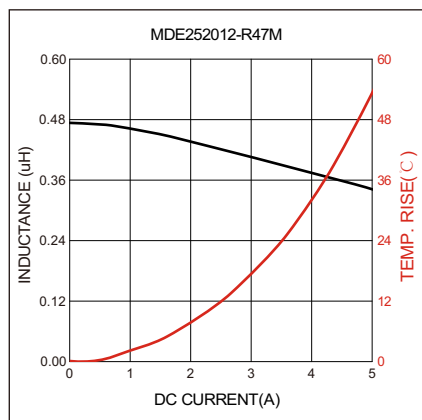

Soldering Reflow:

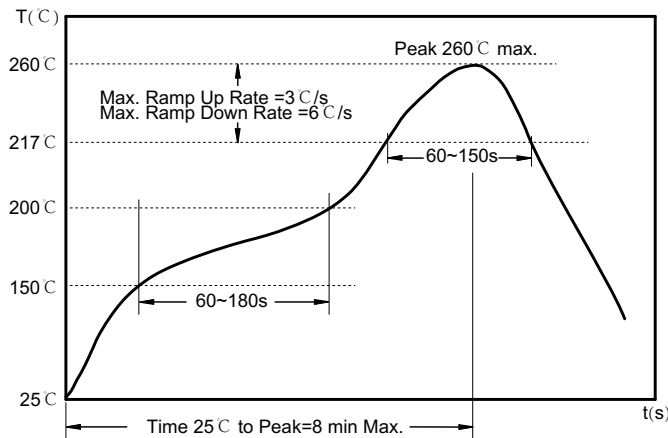

Preheat condition: 150 ~200 °C / 60~180 sec.

Allowed time above 217 °C : 60~150 sec.

Max temperature: 260 °C .

Time within 5 °C of actual Peak Temperature: 20-40 sec.

Packaging Information:

Tape Dimension:

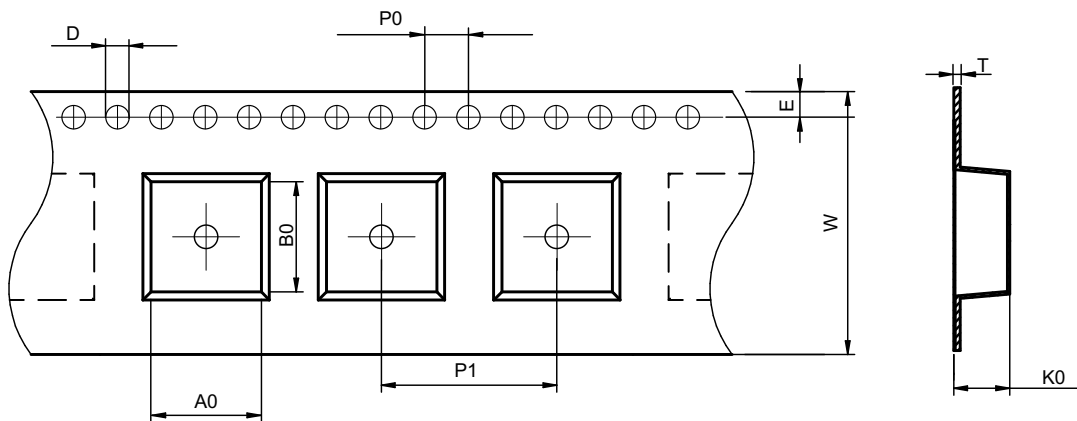

Series	A0 (mm)	B0 (mm)	D (mm)	P0 (mm)	P1 (mm)	W (mm)	K0 (mm)	E (mm)	T (mm)
MDE252012	2.25±0.05	2.80±0.1	1.55±0.05	4.0±0.1	4.0±0.1	8.0±0.3	1.35±0.1	1.75±0.1	0.22±0.05

Peel force of top cover tape:

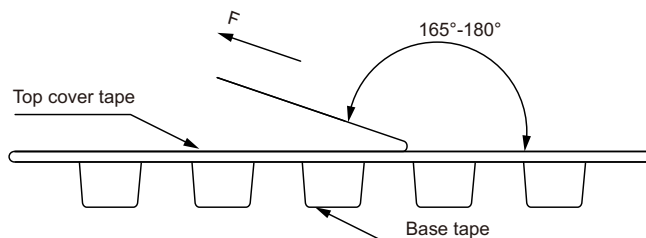

The peel force of top cover tape shall be between 0.1 to 1.3 N

Reel Dimension: [mm]

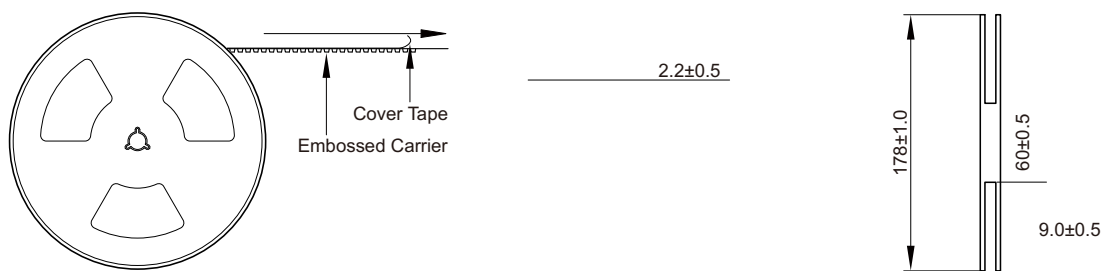

Packaging Quantity:

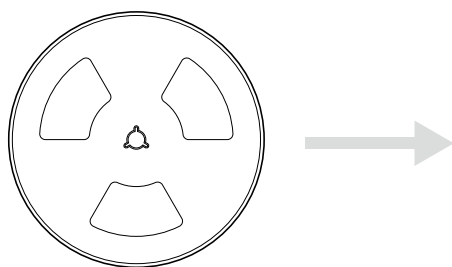

3000 Pcs/Reel

5 Reel /Inner box(15K Pcs)

8 Inner box/Carton box(120K Pcs)

Cautions and Warnings:

Storage Conditions:

-
-
-
-

Q

Q